

REV.	REASON FOR ISSUE	DATE	DRN.	CHKD.
0.00	PRELIM.REL.	12.03.00	D.K.D.	G.G.A
1.00	REL. FOR MANU.	2.08.00	D.K.D.	G.G.A

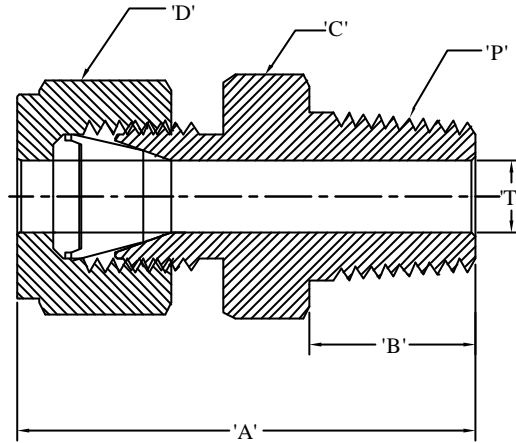

PART NO.	TUBE O.D 'T'	THREAD NPT 'P'	'A'	'B'	HEX A/F 'C'	HEX A/F 'D'
1AMC1-BT	1/16"	1/16"	0.94	0.38	5/16	5/16
1AMC2-BT	1/16"	1/8"	1.03	0.38	7/16	5/16
1AMC4-BT	1/16"	1/4"	1.22	0.56	9/16	5/16
2AMC2-BT	1/8"	1/8"	1.20	0.38	7/16	7/16
2AMC4-BT	1/8"	1/4"	1.40	0.56	9/16	7/16
2AMC8-BT	1/8"	1/2"	1.66	0.75	7/8	7/16
3AMC2-BT	3/16"	1/8"	1.23	0.38	7/16	1/2
3AMC4-BT	3/16"	1/4"	1.43	0.56	9/16	1/2
4AMC2-BT	1/4"	1/8"	1.29	0.38	1/2	9/16
4AMC4-BT	1/4"	1/4"	1.49	0.56	9/16	9/16
4AMC6-BT	1/4"	3/8"	1.51	0.56	11/16	9/16
4AMC8-BT	1/4"	1/2"	1.76	0.75	7/8	9/16
6AMC4-BT	3/8"	1/4"	1.57	0.56	5/8	11/16
6AMC6-BT	3/8"	3/8"	1.57	0.56	11/16	11/16
6AMC8-BT	3/8"	1/2"	1.82	0.75	7/8	11/16
8AMC8-BT	1/2"	1/2"	1.93	0.75	7/8	7/8

ALL DIMENSIONS ARE IN INCHES.

**NOTE:**

- (1) FOR DOUBLE FERRULE ,ADD SUFFIX 'D' TO P/N.
- (2) FOR PTFE ADD SUFFIX PTFE TO P/N.
- (3)PTFE FERRULE AVAILABLE ONLY AS SINGLE FERRULE.

**MATERIAL: 316SS**

<b>PROJECT/CLIENT</b>
<b>TITLE</b>
<b>BORE THROUGH COMPRESSION FITTINGS</b>

**Aura Inc.**  
**D11/3,OKHALA IND. AREA,**  
**PHASE II, NEW DELHI**  
**INDIA.**  
**www.aurainc.com**

This drawing is the property of Aura Inc.  
 Unauthorised reproduction is prohibited.

**DRG NO :AMC-BT-316-001**

REV.	REASON FOR ISSUE	DATE	DRN.	CHKD.
0.00	PRELI. REL.	12.03.01	D.K.D.	G.G.A
1.00	REL. FOR MANU.	12.07.01	D.K.D.	G.G.A

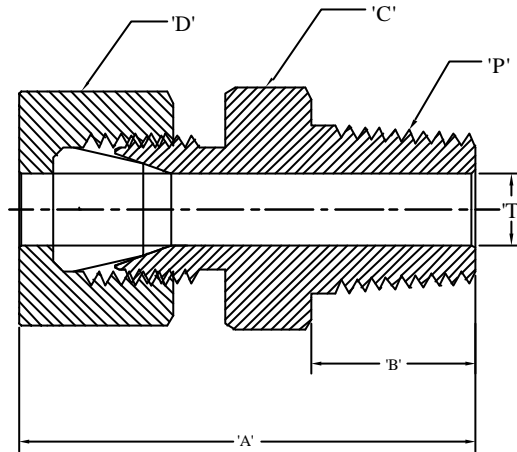

PART NO.	TUBE O.D 'T'	BORE SIZE	THREAD NPT 'P'	'A'	'B'	HEX A/F 'C'	HEX A/F 'D'
1AMC2-BT-BR-X	1/16"	0.069	1/8"	1.2	0.38	7/16	3/8
0.093AMC2-BT-BR-X	1/16"	0.100	1/8"	0.94	0.38	7/16	3/8
2AMC2-BT-BR-X	1/8"	0.131	1/8"	1.2	0.38	3/8	7/16
2AMC4-BT-BR-X	1/8"	0.131	1/4"	1.26	0.50	9/16	7/16
3AMC2-BT-BR-X	3/16"	0.188	1/8"	1.20	0.38	7/16	7/16
3AMC4-BT-BR-X	3/16"	0.188	1/4"	1.30	0.50	9/16	1/2
4AMC2-BT-BR-X	1/4"	0.257	1/8"	1.15	0.38	7/16	1/2
4AMC4-BT-BR-X	1/4"	0.257	1/4"	1.30	0.50	9/16	1/2
6AMC4-BT-BR-X	3/8"	0.382	1/4"	1.40	0.50	5/8	11/16
6AMC8-BT-BR-X	3/8"	0.382	1/2"	1.60	0.70	7/8	11/16

ALL DIMENSIONS ARE IN INCHES.

MATERIAL
BODY & NUT: BRASS
FERRULES : BRASS/PTFE
FERRULE DESIGN: SINGLE

PROJECT/CLIENT
TITLE
BORE THROUGH COMPRESSION FITTINGS
This drawing is the property of Aura Inc. Unauthorised reproduction is prohibited.

<b>Aura Inc.</b> D11/3,OKHALA IND. AREA, PHASE II, NEW DELHI INDIA. www.aurainc.com
DRG NO :AMC-BT-BRX-001